



# Standard Test Methods for Fineness of Hydraulic Cement by Air-Permeability Apparatus<sup>1</sup>

This standard is issued under the fixed designation C204; the number immediately following the designation indicates the year of original adoption or, in the case of revision, the year of last revision. A number in parentheses indicates the year of last reapproval. A superscript epsilon ( $\epsilon$ ) indicates an editorial change since the last revision or reapproval.

## 1. Scope\*

1.1 This test method covers determination of the fineness of hydraulic cement, using the Blaine air-permeability apparatus, in terms of the specific surface expressed as total surface area in square centimetres per gram, or square metres per kilogram, of cement. Two test methods are given: Test Method A is the Reference Test Method using the manually operated standard Blaine apparatus, while Test Method B permits the use of automated apparatus that has in accordance with the qualification requirements of this test method demonstrated acceptable performance. Although the test method may be, and has been, used for the determination of the measures of fineness of various other materials, it should be understood that, in general, relative rather than absolute fineness values are obtained.

1.1.1 This test method is known to work well for portland cements. However, the user should exercise judgement in determining its suitability with regard to fineness measurements of cements with densities, or porosities that differ from those assigned to Standard Reference Material No. 114 or No. 46h.

1.2 The values stated in SI units are to be regarded as the standard.

1.3 **Warning**—*Mercury has been designated by many regulatory agencies as a hazardous substance that can cause serious medical issues. Mercury, or its vapor, has been demonstrated to be hazardous to health and corrosive to materials. Caution should be taken when handling mercury and mercury containing products. See the applicable product Safety Data Sheet (SDS) for additional information. Users should be aware that selling mercury and/or mercury containing products into your state or country may be prohibited by law.*

1.4 *This standard does not purport to address all of the safety concerns, if any, associated with its use. It is the*

*responsibility of the user of this standard to establish appropriate safety, health, and environmental practices and determine the applicability of regulatory limitations prior to use.*

1.5 *This international standard was developed in accordance with internationally recognized principles on standardization established in the Decision on Principles for the Development of International Standards, Guides and Recommendations issued by the World Trade Organization Technical Barriers to Trade (TBT) Committee.*

## 2. Referenced Documents

### 2.1 ASTM Standards:<sup>2</sup>

[A582/A582M Specification for Free-Machining Stainless Steel Bars](#)

[C125 Terminology Relating to Concrete and Concrete Aggregates](#)

[C219 Terminology Relating to Hydraulic and Other Inorganic Cements](#)

[C670 Practice for Preparing Precision and Bias Statements for Test Methods for Construction Materials](#)

[E832 Specification for Laboratory Filter Papers](#)

### 2.2 NIST Standards:<sup>3</sup>

[No. 46h National Institute of Standards and Technology Standard Reference Material](#)

[No. 114 National Institute of Standards and Technology Standard Reference Material](#)

### 2.3 Other Document:

[BS 4359: 1971 British Standard Method for the Determination of Specific Surface of Powders: Part 2: Air Permeability Methods<sup>4</sup>](#)

<sup>1</sup> This test method is under the jurisdiction of ASTM Committee C01 on Cement and is the direct responsibility of Subcommittee C01.25 on Fineness.

Current edition approved April 1, 2023. Published May 2023. Originally approved in 1946. Last previous edition approved in 2018 as C204 – 18<sup>ε1</sup>. DOI: 10.1520/C0204-23.

<sup>2</sup> For referenced ASTM standards, visit the ASTM website, [www.astm.org](http://www.astm.org), or contact ASTM Customer Service at [service@astm.org](mailto:service@astm.org). For *Annual Book of ASTM Standards* volume information, refer to the standard's Document Summary page on the ASTM website.

<sup>3</sup> Available from National Institute of Standards and Technology (NIST), 100 Bureau Dr., Stop 1070, Gaithersburg, MD 20899-1070, <http://www.nist.gov>.

<sup>4</sup> Available from British Standards Institute (BSI), 389 Chiswick High Rd., London W4 4AL, U.K., <http://www.bsi-global.com>.

\*A Summary of Changes section appears at the end of this standard

TEST METHOD A: REFERENCE METHOD

3. Terminology

3.1 Definitions:

3.1.1 For definitions of terms used in this test method, refer to Terminology C125 and C219.

4. Apparatus

4.1 Nature of Apparatus—The Blaine air-permeability apparatus consists essentially of a means of drawing a definite quantity of air through a prepared bed of cement of definite porosity. The number and size of the pores in a prepared bed of definite porosity is a function of the size of the particles and determines the rate of airflow through the bed. The apparatus, illustrated in Fig. 1, shall consist specifically of the parts described in 4.2 - 4.8.

4.2 Permeability Cell—The permeability cell shall consist of a rigid cylinder 12.70 mm ± 0.10 mm in inside diameter, constructed of austenitic stainless steel. The interior of the cell shall have a finish of 0.81 μm (32 μin.). The top of the cell shall be at right angles to the principal axis of the cell. The lower portion of the cell must be able to form an airtight fit with the upper end of the manometer, so that there is no air leakage between the contacting surfaces. A ledge ½ mm to 1 mm in width shall be an integral part of the cell or be firmly fixed in the cell 55 mm ± 10 mm from the top of the cell for support of the perforated metal disk. The top of the permeability cell shall be fitted with a protruding collar to facilitate the removal of the cell from the manometer.

NOTE 1—Specification A582/A582M Type 303 stainless steel (UNS designation S30300) has been found to be suitable for the construction of the permeability cell and the plunger.

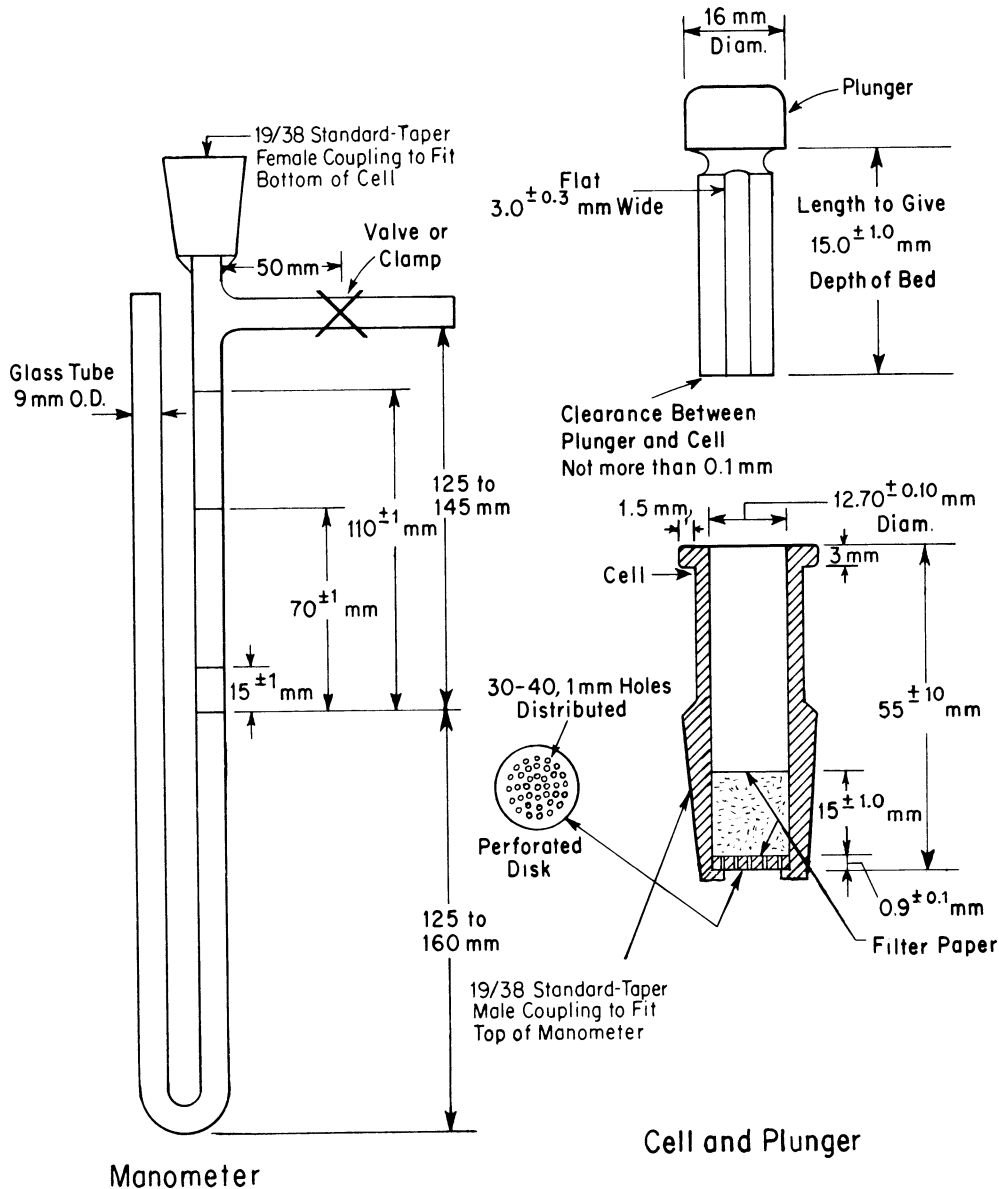

FIG. 1 Blaine Air-Permeability Apparatus

4.3 *Disk*—The disk shall be constructed of noncorroding metal and shall be 0.9 mm ± 0.1 mm in thickness, perforated with 30 to 40 holes 1 mm in diameter equally distributed over its area. The disk shall fit the inside of the cell snugly. The center portion of one side of the disk shall be marked or inscribed in a legible manner so as to permit the operator always to place that side downwards when inserting it into the cell. The marking or inscription shall not extend into any of the holes, nor touch their peripheries, nor extend into that area of the disk that rests on the cell ledge.

4.4 *Plunger*—The plunger shall be constructed of austenitic stainless steel and shall fit into the cell with a clearance of not more than 0.1 mm. The bottom of the plunger shall sharply meet the lateral surfaces and shall be at right angles to the principal axis. An air vent shall be provided by means of a flat 3.0 mm ± 0.3 mm wide on one side of the plunger. The top of the plunger shall be provided with a collar such that when the plunger is placed in the cell and the collar brought in contact with the top of the cell, the distance between the bottom of the plunger and the top of the perforated disk shall be 15 mm ± 1 mm.

4.5 *Filter Paper*—The filter paper shall be medium retentive, corresponding to Type 1, Grade B, in accordance with Specification E832. The filter paper disks shall be circular, with smooth edges, and shall have the same diameter (Note 2) as the inside of the cell.

NOTE 2—Filter paper disks that are too small may leave part of the sample adhering to the inner wall of the cell above the top disk. When too large in diameter, the disks have a tendency to buckle and cause erratic results.

4.6 *Manometer*—The U-tube manometer shall be constructed according to the design indicated in Fig. 1, using nominal 9 mm outside diameter, standard-wall, glass tubing. The top of one arm of the manometer shall form an airtight connection with the permeability cell. The manometer arm connected to the permeability cell shall have a midpoint line etched around the tube at 125 mm to 145 mm below the top side outlet and also others at distances of 15 mm ± 1 mm, 70 mm ± 1 mm, and 110 mm ± 1 mm above that line. A side outlet shall be provided at 250 mm to 305 mm above the bottom of the manometer for use in the evacuation of the manometer arm connected to the permeability cell. A positive airtight valve or clamp shall be provided on the side outlet not more than 50 mm from the manometer arm. The manometer shall be mounted firmly and in such a manner that the arms are vertical.

4.7 *Manometer Liquid*—The manometer shall be filled to the midpoint line with a nonvolatile, nonhygroscopic liquid of low viscosity and density, such as dibutyl phthalate (dibutyl 1,2-benzene-dicarboxylate) or a light grade of mineral oil. The fluid shall be free of debris.

4.8 *Timer*—The timer shall have a positive starting and stopping mechanism and shall be capable of being read to the nearest 0.5 s or less. The timer shall be accurate to 0.5 s or less for time intervals up to 60 s, and to 1 % or less for time intervals of 60 to 300 s.

## 5. Calibration of Apparatus

5.1 *Sample*—The calibration of the air permeability apparatus shall be made using the current lot of NIST Standard Reference Material No. 114 or 46h. The sample shall be at room temperature when tested.

5.2 *Bulk Volume of Compacted Bed of Powder*—Determine the bulk volume of the compacted bed of powder by physical measurement or by the mercury displacement method as follows:

5.2.1 *Bulk Volume Determination by Physical Measurement*—Place two filter papers in the permeability cell. Use a rod slightly smaller than the diameter of the cell to press down the edges of the filter paper flat on the perforated disk. Determine the dimensions of the permeability cell, in cm, using a measuring device readable to 0.001 cm. Measure the inside diameter of the permeability cell near the perforated disk. Measure the depth of the cell and the length of the plunger. Take three measurements of each dimension and use the average value of each dimension to calculate the bulk volume as follows:

$$V = \pi r^2 h \quad (1)$$

where:

$V$  = bulk volume occupied by sample, cm<sup>3</sup>,  
 $r$  = diameter cell/2, cm, and  
 $h$  = cell depth – plunger length, cm.

5.2.2 *Bulk Volume Determination by the Mercury Displacement Method*—Place two filter paper disks in the permeability cell, pressing down the edges, using a rod having a diameter slightly smaller than that of the cell, until the filter disks are flat on the perforated metal disk; then fill the cell with mercury, ACS reagent grade or better, removing any air bubbles adhering to the wall of the cell. Use tongs when handling the cell. If the cell is made of material that will amalgamate with mercury, the interior of the cell shall be protected by a very thin film of oil just prior to adding the mercury. Level the mercury with the top of the cell by lightly pressing a small glass plate against the mercury surface until the glass is flush to the surface of the mercury and rim of the cell, being sure that no bubble or void exists between the mercury surface and the glass plate. Remove the mercury from the cell and measure and record the mass of the mercury. Remove one of the filter disks from the cell. Using a trial quantity of 2.80 g of cement (Note 3) compress the cement (Note 4) in accordance with 5.5 with one filter disk above and one below the sample. Into the unfilled space at the top of the cell, add mercury, remove entrapped air, and level off the top as before. Remove the mercury from the cell and measure and record the mass of the mercury.

5.2.3 Calculate the bulk volume occupied by the cement to the nearest 0.005 cm<sup>3</sup> as follows:

$$V = (W_A - W_B)/D \quad (2)$$

where:

$V$  = bulk volume of cement, cm<sup>3</sup>,  
 $W_A$  = grams of mercury required to fill the cell, no cement being in the cell,